

Pb Free Plating Product

S10U50S



10 Ampere Lower VF Miniature Surface Mount Schottky Barrier Rectifier

Features

- High surge Forward current capability
- Low Power loss, High efficiency
- IF (AV) 10A
- VRRM 50V

Applications

- Switching Power Supply Industry
- Photovoltaic Solar cell Protection Schottky Rectifier

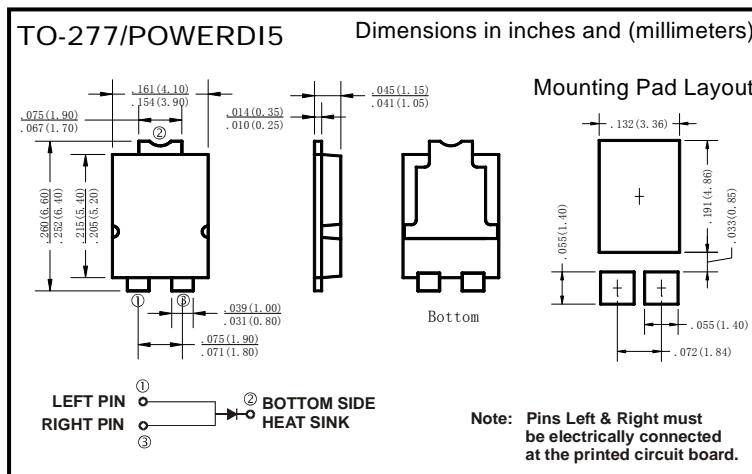

Limiting Values (Absolute Maximum Rating)

Item	Symbol	Unit	Conditions	S10U50S
Repetitive Peak Reverse Voltage	VRRM	V		50
Average Rectified Output Current	Io	A	60HZ sine wave, R- load, Ta=25°C	10
Surge(Non-repetitive)Forward Current	IFSM	A	60HZ sine wave, 1 cycle, Ta=25°C	200
Current Squared Time	i ² t	A ² s	1ms ≤ t < 8.3ms Tj=25°C	166
Storage Temperature	Tstg	°C		-55 ~ +150
Junction Temperature	Tj	°C		-55~+150
Thermal Resistance(Typical)	RθJ-C	°C/W	Between Junction and Case	10

Electrical Characteristics (Ta=25°C Unless otherwise specified)

Item	Symbol	Unit	Test Condition	Min	Typ	Max
Peak Forward Voltage	VFM	V	IFM =10.0A, Tj=25°C	-	0.41	0.47
			IFM =10.0A, Tj=125°C	-	0.37	0.40
Reverse Breakdown Voltage	VBR	V	IR=0.5mA	50	-	-
Leakage Current	IR	mA	VR=50V, Tj=25°C	-	-	0.5
			VR=50V, Tj=125°C	-	-	100

Rating and Characteristic Curves

